

STATE OF THE ART ASSESSMENT OF COMPOSITE SYSTEMS USED TO REPAIR TRANSMISSION PIPELINES

Chris Alexander
Stress Engineering Services, Inc.
Houston, Texas
chris.alexander@stress.com

Bob Francini
Kiefner & Associates, Inc.
Worthington, Ohio
bfrancini@kiefner.com

ABSTRACT

For the past decade there has been relatively wide acceptance in using composite materials to repair damaged gas and liquid transmission pipelines. There have been numerous independent research programs performed by pipeline companies, research organizations, and manufacturers that have contributed to the acceptance of composites as a legitimate repair material. Additionally, insights have been gained by both pipeline operators and composite repair manufacturers during field installations. ASME has also responded by adding sections to both the ASME B31.4 and B31.8 pipeline codes, as well as currently developing a repair standard for non-metallic composite repair systems by the Post Construction Committee.

Stress Engineering Services, Inc. and Kiefner & Associates, Inc. have been integrally involved in assessing the repair of pipeline systems, with the former having been involved in performing full-scale testing and analysis on most of the major U.S.-based composite repair systems. The purpose of this paper is to provide for the pipeline industry a third-party evaluation of composite repair systems and information that is needed to properly evaluate how composite materials should be used to repair high pressure pipelines. The contents of the paper will include discussions on what critical elements should be evaluated for each composite system, items of caution and concern, and the importance of evaluation to ensure safe long-term performance.

BACKGROUND AND HISTORY

There were three principal driving forces that led to the interest and investment in composite materials in the United States in the mid-1950s and 1960s: the designer's demand for lower weight and higher rigidity for aero- or space structures, electronics, sports equipment, and other applications; the solid-state theory's predictions of extremely high potential crystal strengths, more than one million psi tensile strengths, and elastic moduli of more than 100 million psi; and the flourishing U.S. economy.

Advanced composites had come of age in the early 1960s with the development of high-modulus whiskers and filaments. While whiskers were easily made, their composites were of poor quality; but the 60 million modulus boron filaments reinforcing epoxy were very successful and were used in fighter aircraft and later in sporting goods equipment [1]. As their costs came down over the years, the use of composites has migrated to oil and gas applications, including pipeline repair.

From a transmission pipeline standpoint, Clock Spring® is clearly recognized as the first composite repair system that was widely used to repair pipelines. In 1991 the Gas Research Institute (GRI) initiated a research program at Southwest Research Institute (San Antonio, Texas) and Battelle Columbus Division (Columbus, Ohio) to thoroughly test a composite repair system that had been developed by industry. Over the next five years an intense research effort was carried out to assess the performance of Clock Spring® that utilized an E-glass/polyester material and methacrylate adhesive.

In order to use composite materials to repair transmission pipelines, the Office of Pipeline Safety (OPS) required the use of waivers before installations could take place [2].

First, OPS granted the Panhandle Eastern Corporation a waiver of § 192.713(a) to install Clock Spring® over six corrosion anomalies on Line #2 in Ohio, subject to certain monitoring and reporting conditions (58 FR 13823; March 15, 1993). Then OPS granted 28 interstate operators and their subsidiaries a waiver of §§ 192.485(a) and 192.713(a) to install Clock Spring® on transmission line pipe operating at 40 percent or more of SMYS, provided the operators follow the manufacturer's installation procedures, use GRIWrap (a computer program that determines if a defect is suitable for Clock Spring® repair), participate in GRI's evaluation plan, notify OPS and state interstate agents of planned installations, and use trained installers (60 FR 10630; February 27, 1995). Next OPS extended the February 27th waiver to include six more interstate operators (60 FR 47800; September 14, 1995). Subsequently, OPS authorized a few additional interstate operators to apply the February 27th waiver and approved similar waivers granted intrastate operators by state pipeline safety agencies in Illinois, Wyoming, and Minnesota.

In many regards, Clock Spring® set the standard in terms of expectations associated with the development of composite repairs. GRI was instrumental in gathering both industry and research partners for evaluating the repair system. Some of these efforts involved the following activities:

- Composite material testing and analysis including short and long-term stress-rupture testing
- Adhesive testing in terms of lap shear strengths
- Burst test considering general defects, circumferential defects, long axial defects, and repair of dents, gouges, and mechanical damage.

- Field exposure assessment of Clock Springs installed in 1989 (coupon testing and inspection of installed wraps)
- Development of GRIWrap™ to provide a general procedure for the safe application of Clock Spring®.

A final report for GRI, *Development of Fiberglass Systems for Natural Gas Pipeline Service*, was prepared by NCF industries [3]. This document spanned a period of time from January 1987 to March 1994 and covered the basic history and development of Clock Spring®.

During the 1990s GRI continued numerous research efforts that included field validation efforts [4], long-term-reliability efforts [5], and repair of non-straight pipe geometries such as elbows [6].

In the mid-1990s, industry began using wet lay-up systems. The first system on the market was a private label product known as *StrongBack* that is manufactured by Air Logistics Corporation (Azusa, California). *StrongBack* is a composite reinforcement products that is water activated, resin impregnated, and uses glass fiber remediation materials. In the past several years, Air Logistics has also brought to industry an additional water-activated system, *Aquawrap*™. This system has undergone extensive testing, including full-scale testing to address its use in repairing mechanical damage [7].

In 1997, Armor Plate, Inc. started a research program to develop the *Armor Plate*® Pipe Wrap system [8]. Stress Engineering Services, Inc. was involved in the testing of this system, which employs a fiberglass material that is impregnated with unique epoxy systems to address specific environmental conditions, such as underwater applications, high temperatures, and cold weather.

Prior to 2000, pipeline companies were generally hesitant to use products other than *Clock Spring*® because of waiver requirement (refer to details in following section of this paper). However, effective January 13, 2000, the Office of Pipeline Service (OPS) permitted the use of composite materials as long as the following criterion was satisfied in terms of repairing dents and corrosion [10].

... repaired by a method that reliable engineering tests and analyses show that can permanently restore the serviceability of the pipe.

Additionally, this document addressed issues relating to industry expectations as reflected in the following statement.

*We recognize that licensed professional engineers may differ on what information is necessary to demonstrate the performance of particular technologies in particular circumstances. But the experience of *Clock Spring*® and *Armor Plate* wraps can serve as a model in determining the technical issues to resolve and the relevant substantiating tests and analyses.*

Once the 2000-edition of the OPS ruling came out, use of composite materials in repairing pipelines increased significantly. In a similar fashion, the number of manufacturers interested in this repair technology also increased.

In 2000 *WrapMaster*, Inc. started a testing program to assess the capabilities of *PermaWrap*™, which is a system similar to *Clock Spring*® in that it employs a hard shell with an adhesive installed between layers. The following product description is provided according to the GE Power web site [9].

*The *Wrapmaster* repair system is a coil of high-strength composite material with a configuration that allows it to wrap*

*tightly around pipe of almost any size. The layers of wrap are sealed together with a strong adhesive. The defect is filled with adhesive filler to assist with support and load transfer prior to the *Wrapmaster* installation. This method of repair is ideal for blunt-type defects. It is not suitable for internal defects, sharp crack-like defects or girth weld or circumferential defects. The *Wrapmaster* repairs are magnetic pig detectable and are available in a range of widths.*

T.D. Williamson, Inc. has developed the *Black-Diamond*™ Composite Wrap. Although similar in nature to *Armor Plate*® Pipe Wrap in its use of epoxy products, the T.D. Williamson system has the added strength advantage of using Carbon fibers, which on average have an elastic modulus that is approximately twice that of conventional E-glass.

Numerous other companies are continuing to pursue the development of products of this repair genre. With improved innovations and technology, along with proper use of engineering evaluation methods and testing, the pipeline industry will benefit. The focus must remain on the requirement that these composite systems permanently restore the serviceability of pipelines.

CODES, STANDARDS, AND REGULATIONS

With the widespread use of composite materials, both the government and pipeline industry have been required to address this innovative technology. Although there are numerous world-wide standards associated with repair using composite materials, the authors have elected to focus on U.S.-based regulations and standards. These include:

- ASME B31.4 (liquid pipelines)
- ASME B31.8 (gas pipelines)
- U.S. D.O.T. Office of Pipeline Safety Regulations

ASME B31.4 - Pipeline Transportation Systems for Liquid Hydrocarbons and Other Liquids

In terms of composite usage the following statement is made in ASME B31.4.

451.6.2 Disposition of Defects

(c) Repair Methods

(14) Mechanically applied composite material wrap may be used to reinforce the pipeline provided that design and installation methods are proven for the intended service prior to application. The user is cautioned that a qualified written procedure performed by trained personnel is a requirement and records shall be retained...

ASME B31.8 - Gas Transmission and Distribution Piping Systems

In terms of composite usage the following statement is made in ASME B31.8.

851.42 Permanent Field Repairs of Injurious Dents and Mechanical Damage

(e) Nonmetallic composite wrap repairs are not acceptable for the repair of injurious dents or mechanical damage, unless proven through reliable engineering tests and analysis.

Office of Pipeline Safety Regulations

The U.S. Department of Transportation's new pipeline repair rule went into effect on January 13, 2000. Prior to this rule, pipeline companies had to obtain a waiver from the DOT to use Clock Spring® and no other composite repair methods were officially permitted. Two sections of the regulations addressed repair of dents and corrosion. Text from the regulation are provided in the sections below as follows, respectively (underlining added by authors).

§ 192.309 Repair of steel pipe.

(b) Each of the following dents must be removed from steel pipe to be operated at a pressure that produces a hoop stress of 20 percent, or more, of SMYS, unless the dent is repaired by a method that reliable engineering tests and analyses show can permanently restore the serviceability of the pipe:

§ 192.485 Remedial measures:

Transmission lines.

(a) General corrosion. Each segment of transmission line with general corrosion and with a remaining wall thickness less than that required for the MAOP of the pipeline must be replaced or the operating pressure reduced commensurate with the strength of the pipe based on actual remaining wall thickness. However, corroded pipe may be repaired by a method that reliable engineering tests and analyses show can permanently restore the serviceability of the pipe. Corrosion pitting so closely grouped as to affect the overall strength of the pipe is considered general corrosion for the purpose of this paragraph.

FUNDAMENTALS OF COMPOSITE REPAIR SYSTEMS

Having provided a brief history on the development of composite repair systems and an overview of the existing codes, standards, and regulations, it is appropriate to discuss the fundamental mechanical issues associated with composite repair systems

Types of Repair Systems

In general, there are currently two types of composite repair systems that are employed by most manufacturers: *layered systems* and *wet lay-up systems*. All composite repair systems employ some type of fiber system that provides strength and stiffness (typically glass or carbon fibers), a resin matrix used to transfer load between fibers, and in the case of layered systems, an adhesive that is used to bond layers. The sections below provide a brief overview of these two main repair systems.

Layered Systems

Layered systems involve bonding of a pre-cured system that is held together with an adhesive applied in the field. Based on prior research using strain gages installed in between different layers, it is clear that variations in strain exist between the different layers. Additionally, the same research showed that a bulk of the load is carried by the inner layers and that the outer layers provided redundancy in terms of overall reinforcement. The Clock Spring® and PermaWrap systems are examples of layered systems. Repair using these systems is generally limited to straight sections of pipe.

Wet Lay-up Systems

The more recent composite systems have employed a wet lay-up system. These systems typically involve some type of fiberglass or carbon fiber cloth which is saturated in the field (e.g. Armor Plate® Pipe Wrap and Black-Diamond™ Composite Wrap). Other variations

of the wet lay-up system involve pre-impregnated cloth that is activated in the field by water. These systems have the advantage that their cure state tends to be monolithic and they can be used to cover a range of geometries including tees, elbows, bends, and even valves.

Design Methods

When designing a repair system using composite materials, engineers must consider both strength and stiffness. From a composite standpoint, strength relates to the tensile strength of a particular system, while the stiffness relates to elastic modulus. For most conventional repair systems there is a direct correlation. For example, a uniaxial E-glass system will typically have an elastic modulus on the order of 5×10^6 psi to 6×10^6 psi. The strain to failure for E-glass is on the order of 2 percent. Therefore one can conclude that typical failure stresses for uniaxial E-glass systems are between 100 ksi and 120 ksi. Carbon fibers are more stiff (i.e. higher modulus); however, their strain to failure is approximately half that of E-glass.

It is worth noting that elastic modulus is related primarily to fiber type, orientation, and volume fraction. In a layered system, one must consider the contribution of the adhesive. Based on questions posed to the authors, it is clear that there is some confusion on this issue. Unless a perfect bond exists between layers, inefficiencies are introduced in terms of the actual elastic modulus. As an example, it is possible for a composite to have an elastic modulus at the lamina level of 5×10^6 psi; however, with the introduction of adhesives the elastic modulus can be reduced to approximately one-half this value, or 2.5×10^6 psi

Recognizing the importance of stiffness, development of a composite repair system must consider the elastic modulus. This is especially important when considering the level of reinforcement provided to the carrier pipe, which is typically steel. Consider a non-reinforced steel pipe that has a diameter to wall thickness ratio greater than 20. Barlow's equation, based on shell theory, is used to calculate circumferential (hoop) stress in the pipe.

$$\sigma_{hoop} = \frac{PR}{t}$$

Where	P	Internal pressure (psi)
	R	Mean pipe radius (inches)
	t	Wall thickness (inches)
	σ_{hoop}	Hoop stress in pipe (psi)

When a pipe is repaired using a composite material, the stress in the carrier pipe is reduced in proportion to the reinforcement provided by the composite material. At the interface, circumferential strains in the pipe and composite reinforcement materials are equal. Using compatibility and first principles, the *modified* circumferential stresses in the carrier pipe is calculated using the following relation.

$$\sigma_{hoop} = \frac{PR}{t_p \left[1 + \frac{E_c t_c}{E_p t_p} \right]}$$

Where	t_p	Pipe wall thickness (inches)
	E_p	Pipe elastic modulus (psi)
	t_c	Composite material thickness (inches)
	E_c	Composite material elastic modulus (psi)
	σ_{hoop}	Hoop stress in pipe (psi)

It is clear from the previous expression that the stress in the carrier pipe is reduced in proportion to the ratio of the pipe stiffness (i.e. $E_{pt,p}$) to the composite stiffness (i.e. $E_c t_c$). If one considers a composite repair that is 0.6 inches thick with an elastic modulus 2×10^6 psi, the hoop stress in a steel pipe that is 0.2 inches thick is reduced by 16 percent over the non-reinforced condition. However, if the composite elastic modulus is increased to 5×10^6 psi (0.6 inches thick as before), the hoop stress is reduced by 33 percent.

At the present time there are no minimum tensile strengths or specified minimum elastic moduli; however, it is clear from the above discussion that to be effective in repairing and reinforcing steel pipelines, composite materials should have adequate stiffness. A good rule of thumb, or target strength/stiffness combination value, is to have a material with a modulus on the order of 2.5×10^6 psi and a tensile strength on the order of 50,000 psi. As will be discussed later, design considerations must also consider long-term performance as well as time and temperature-dependant material degradation issues.

Load Transfer between Steel and Composite

In the spirit of discussions associated with design for strength and stiffness, one must consider load transfer between the steel and composite during internal pressurization of the pipe. Both Clock Spring® and Armor Plate® Pipe Wrap have performed numerous experimental investigations to assess the load transfer mechanism. Figure 1 shows a free body diagram of a reinforced pipe, while Figure 2 is a plot showing the differences in strain state between a reinforced and non-reinforced corrosion defects. As shown in this plot obtained for pressure testing on a 16-inch x 0.375-inch pipe having 50 percent corrosion (8-inch x 8-inch patch) fitted with strain gages beneath the composite repair, when the pipe starts to yield at 0.2 percent, the load is transferred from the steel pipe to the composite material. Yielding in the pipe is clearly the demarcation point at which the load transfer takes place. A similar series of plots shown in Figure 3 and 4 are based on work performed by Battelle for GRI considering the reinforcement provided by Clock Spring® [5]. These results take into account yielding of the pipe prior to installation of Clock Spring. As shown in Figure 4, six specific load steps are designated. The key point is to observe the increased stiffness in the response of the pipe once Clock Spring® was installed.

It should be noted that the stiffness ($E \cdot t$) of the composite material plays an integral role in determining the strain level at which the load transfer will take place. If a composite material is used that has a low stiffness, it is possible that irreparable damage could be inflicted to a corroded, reinforced steel pipe when subjected to high pressures. Experience has shown that elastic modulus (of at least 1,000,000 psi) is a good benchmark for predicting the in situ performance of a composite repair. It is typically recommended that elastic modulus be determined for a material via mechanical testing prior to performing any testing involving actual pipe materials.

Thoughts for Additional Consideration

In addition to issues relating to conventional design analyses, there are other special topics that should be considered as part of the design/evaluation process. Most of the topics listed below have been addressed in previous research programs performed on either Clock Spring® or Armor Plate® Pipe Wrap. Manufacturers and users are encouraged to consider the effects of these tests on the more recent composite repair systems.

- Effects of pressure at the time of installation

- Address strain distribution within the repair matrix for a layered repair system and consider effects of long-term cyclic pressure service
- Effects of cyclic pressure on burst strength of repaired pipe
- Effects of steel surface preparation on performance of repair
- Temperature effects on the strength of the resin/adhesive system
- Repair on non-straight pipe sections including elbows, tees, and pipe bends (refer to Figure 5 and Figure 6).

GUIDELINES

The introduction of composite pipeline repair methods has been a source of great interest over the past several years. The primary aim of these repair methods is to reinforce the damage done to pipelines by both corrosion and mechanical damage (such as dents and gouges), while alleviating the need for welding and in some cases repairing with pressure in the pipeline. Typically, these repair processes involve issues such as the following,

- Restoring the strength of a damaged pipe to the point where its burst pressure is increased to some minimum amount (idealistically 100 percent of the undamaged burst pressure)
- Reducing the strain in the damaged areas of the pipe by providing reinforcement and increased stiffness to the region in question
- Providing a restraint so that leak-before-break occurs (prevents failure by rupture), due to local cracks developed as a result of corrosion or crack propagation in a dent or gouge.
- Sealing the damaged area of the pipe from further development of corrosion.

This section of the paper is designed to provide the reader with an understanding of the critical issues associated with the development and/or evaluation of a composite pipeline repair system. The following list compiled by the authors reflects the minimum requirements that any composite repair should meet.

1. The composite material used in the repair system should possess sufficient tensile strength. The combination of the remaining pipe wall and composite material should possess a long term failure strength that is at least equal to the specified minimum yield strength (SMYS) of the pipe material. Although a strength equal to 100 percent SMYS is sufficient, one option is to recommend that a safety factor be placed on the maximum operating pressure (MOP) and determine the required number of wraps based on this pressure. If MOP is assumed to be 72 percent, a safety factor of two corresponds to a stress level of 144 percent SMYS. While this may be an overly-conservative safety factor, the unknowns relating to the long-term performance of composites in aggressive soil environments require that a conservative position be taken.
2. The material should demonstrate that it can perform adequately in repairing corroded pipelines. This involves strength in burst mode, but also involves ensuring that the repair does not degrade with time or cyclic pressure service. Experimental testing must be conducted to address this issue. In addressing the effects of cyclic operating pressures, the service conditions in actual operating lines should be considered. A typical liquid pipeline may experience approximately 1,800 cycles per year (at a 200 psi pressure differential), while gas transmission lines see 10 times fewer, or 60 cycles, for the same pressure level.
3. Testing should be conducted to address long term behavior of the material under dead weight loading. Idealistically, a battery of tests should be conducted using weights as a percentage of the lower bound failure load for the given material. The testing

should be conducted so that failures occur over loading time periods up to 1,000 hours at a minimum (longer if possible).

4. Lap shear testing should be conducted to ensure that an adequate bond exists between the pipe and wrap. For composite repair methods that are not monolithic (monolithic meaning that all layers combine to form a homogenous unit), these tests should also include composite-composite test samples as well as the composite-steel test coupons. The composite-composite sample is used to assess the bond strength between the layers, while the composite-steel samples are used to determine the lap shear strength at the interface between the pipe material and composite.
5. Testing should be conducted to address cathodic disbondment and the system should meet the requirements as set forth in ASTM G8 (Standard Test Methods of Cathodic Disbonding for Pipeline Coatings).
6. Repair materials should resist mild acid and alkaline environments, including a range of 4 to 11 pH. Alkaline soils may have a pH of 11 or higher, which will attack fiberglass and polyester resin. In general, epoxies can handle mild acids and strong alkalines.
7. Testing should be conducted to address water penetration into the system using test method ASTM G9 (Standard Test Method for Water Penetration and Pipeline Coatings).
8. The composite material should be able to withstand temperatures of the operating line on which it is to be installed. The operator should consider the effects of temperature in selecting regions of application (e.g. compressor station may see temperatures of 200F).
9. Product must be environmentally-safe and possess low toxicity for the applicator.
10. To minimize the possibility for improper installation, the system must be user-friendly and have instructions that are easily understood. For two-part systems, the greatest problem associated with improper application involves incorrect mixing of the adhesive. Installation should only be conducted by a certified applicator.
11. The product must have clearly stated on it the expiration date (if applicable) of any component within the system. The system must demonstrate that it possesses adequate strength over a long period of time (2 to 3 year testing period). This should involve testing of the composite itself as well as adhesive bonds under load. Samples should be exposed to harsh environments (such as saturation in water) where composite properties are known to degrade with time.
12. A field monitoring program should be conducted to assess performance of the wrap over several years. This involves inspection of the buried line at least one year after installation. The repair should be inspected for soundness and any possible signs of degradation. If possible, strain gages should be installed beneath the wrap to determine any changes in the pipe strain that occur with time.
13. The adhesive system must demonstrate that it can be used in a variety of temperature environments and permit installation in a range of ambient temperature conditions (e.g. between 0F and 120F). Ultimate responsibility is on the operator to ensure that the system can adequately cure and is not damaged at elevated ambient conditions.
14. For cold weather applications, the system should have sufficient toughness to ensure that the material does not become brittle and lose its ability to properly reinforce the pipeline.
15. When a repair method is used for restoring corroded pipes, calculations relating to its strength should incorporate severity of

the corrosion using methods such as those used in ANSI/ASME B31G. This is especially important considering that most of the wet lay-up system permit the number of wraps to be varied depending on the severity of corrosion level.

It should be noted that many of the above items are included in the upcoming repair standard developed by ASME (and discussed in the following section of this paper).

UPCOMING STANDARDS FOR COMPOSITES

In addition to the existing pipeline design codes and standards, several years ago ASME recognized the need for a standard for the use of composites in the repair of pipework and pipelines. A project team was established within the Post Construction / Subcommittee-Repair and Testing codes and standards activity of the ASME to review the problem and develop an appropriate repair standard. The project team has recently completed and approved its first document, *PCC-2 Article 4.1, Non-Metallic Composite Repair Systems for Pipelines and Pipework: High Risk Applications*. This Article covers two aspects of composite repair systems: material qualification and repair design methodology. The Article applies to two repair situations, corrosion defects and defects with leaks.

The case of pipe defects with dents, gouges, or dents with gouges are not covered in the current version. The ASME PCC project team is continuing work on the Article and is considering the dent-gouge defect case for inclusion in future revisions.

The project team has also developed and approved an Article for low risk applications, *PCC-2 Article 4.2, Non-Metallic Composite Repair Systems for Pipelines and Pipework: Low Risk Applications*. These two Articles will be published shortly as part of the initial issue of PCC-2, Repair of Pressure Equipment and Piping Standard (includes repair articles on welded repairs, mechanical repairs, nonmetallic / bonded repairs, and examination / testing).

One of the advantages in the development of these standards is that a uniform criterion is established for all existing and future composite repair systems. By bringing all of the general requirements and guidelines within one single document, the pipeline industry can recommend to manufacturers the minimum requirements for using composite materials to repair pipelines. By going through this process, pipeline companies and composite repair manufacturers can work together to ensure the continued safe operation of pipelines.

FUTURE USE OF COMPOSITE REPAIRS

For almost 20 years, research efforts have been undertaken to address the performance of composite materials in repairing corroded and mechanically-damaged pipelines. Through these efforts, a great deal has been learned by researchers, manufacturers, and operators on how to correctly repair pipelines.

To establish the permanency of the repair, manufacturers and industry should conduct long-term field studies (and possibly short-term accelerated testing to simulate long-term conditions) to address long-term performance. Ideally, the evaluation should involve buried pipes that are pulled out at specified intervals and burst tested. Although it is common to extrapolate short-term data, it would be beneficial for some research efforts to perform true long-term testing planned for 10 and even 20 plus years.

Qualified systems should satisfy the litmus tests which require that reliable engineering tests and analyses show can permanently restore the serviceability of the pipelines. As long as quality control measures are taken, there is no reason to believe these systems will not serve as they were originally intended. Industry is encouraged to ensure that high levels of quality control are maintained considering both materials and installation techniques.

ACKNOWLEDGEMENTS

The authors would like to express their appreciation to Mr. Franz Worth and Mr. Wes Rowley who provided information regarding the direction and status of the ASME PCC-2 committee that is currently overseeing the development of the forthcoming standard on composite repair systems.

REFERENCES

[1] Scala, E. P., (1996), *A Brief History of Composites in the U.S.—The Dream and the Success*, Journal of Materials, publication of The Minerals, Metals & Materials Society, Vol. 48 No. 2, pp. 45-48.

[2] *Pipeline Safety: Gas and Hazardous Liquid pipeline Repair*, Federal Register, Vol. 64, No. 66, Wednesday, April 7, 1999, Proposed Rules, Department of Transportation, Research and Special Programs Administration, Docket No. RSPA-98-4733, Notice 1.

[3] Fawley, N. C., *Development of Fiberglass Composite Systems for Natural Gas Pipeline Service*, Final Report prepared for the Gas Research Institute, GRI-95/0072, March 1994.

[4] Stephens, D. R. and Kilinski, T. J., *Field Validation of Composite Repair of Gas Transmission Pipelines*, Final Report to the Gas Research Institute, Chicago, Illinois, GRI-98/0032, April 1998.

[5] Kuhlman, C. J., Lindholm, U. S., Stephens, D. R., Kilinski, T. J., and Francini, R. B., *Long-Term Reliability of Gas Pipeline Repairs by Reinforced Composites*, Final Report to the Gas Research Institute, Chicago, Illinois, GRI-95/0071, December 1995.

[6] Block, N., and Kishel, J., *Clock Spring® Reinforcement of Elbow Fittings*, Topical Report prepared for the Gas Research Institute, GRI-93/0346, December 1995.

[7] Alexander, C. R., Pitts, D. A., *Evaluation of the Aquawrap™ System in Repairing Mechanically-damaged Pipes*, report prepared for Air Logistics Corporation, Azusa, California, September 2005.

[8] Alexander, C.R., Wilson, F.D., *Recent Test Results and Field Experience with Armor Plate® Pipe Wrap Repairing Corroded and Mechanically-Damaged Pipes*, 2000 Pigging Conference, Houston, Texas, February 2000.

[9] GE Power web site (<http://www.gepower.com>).

[10] *Pipeline Safety: Gas and Hazardous Liquid pipeline Repair*, Federal Register, Vol. 64, No. 239, Tuesday, December 14, 1999, Rules and Regulations, Department of Transportation, Research and Special Programs Administration, Docket No. RSPA-98-4733; Amdt. 192-88; 195-68 (Effective date: January 13, 2000).

[11] American Society of Mechanical Engineers, *Manual for Determining the Remaining Strength of Corroded Pipelines*, ASME B31G-1991, New York, New York, 1991 edition.

[12] American Society of Mechanical Engineers, *Liquid Transportation System for Hydrocarbons, Liquid Petroleum Gas, Anhydrous Ammonia and Alcohols*, ASME B31.4, New York, New York, 2003 edition.

[13] American Society of Mechanical Engineers, *Gas Transmission and Distribution Piping Systems*, ASME B31.8, New York, New York, 2003 edition.

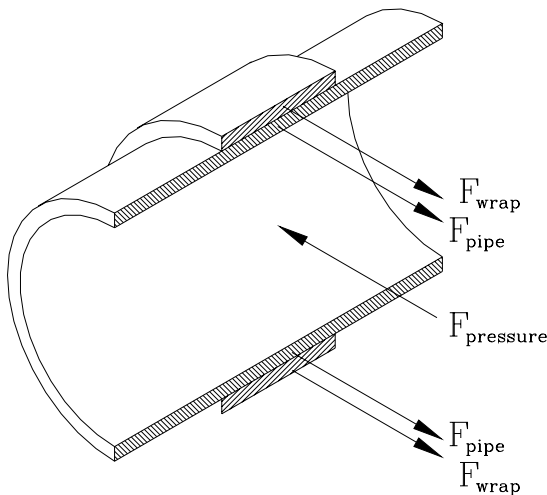

Equation defining burst pressure

$$P_{burst} = \frac{\sigma_{ult_{pipe}} \cdot t_{pipe} + \sigma_{ult_{wrap}} \cdot t_{wrap}}{r_{inside}}$$

- P = Internal pressure
- σ = Material failure stress
- t = Thickness of material
- r = Radius of pipe

Note:
The above calculation is based on thin-wall shell theory and is not applicable for thick-walled pipes with diameter to wall thickness ratios less than 20.

Figure 1 – Free body diagram of composite repair system and pipe

Hoop Stress versus Internal Pressure

16-inch x 0.375-inch, Grade X52 pipe with 50 percent simulated corrosion
 Measurement made using strain gages installed on pipe beneath APPW repair

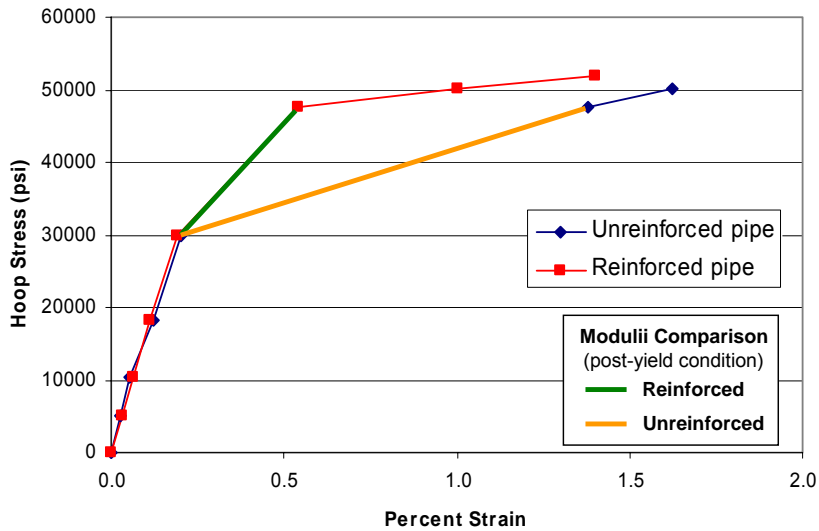

Figure 2 – Load transfer between steel carrier pipe and Armor Plate Pipe Wrap composite material [8]

Strain in Pipe versus Internal Pressure

24-inch x 0.281-inch, Grade X52 pipe with 2 wraps of Clock Spring installed
 (data extracted from report GRI-95/0071, Figure 4.4, page 4.8)

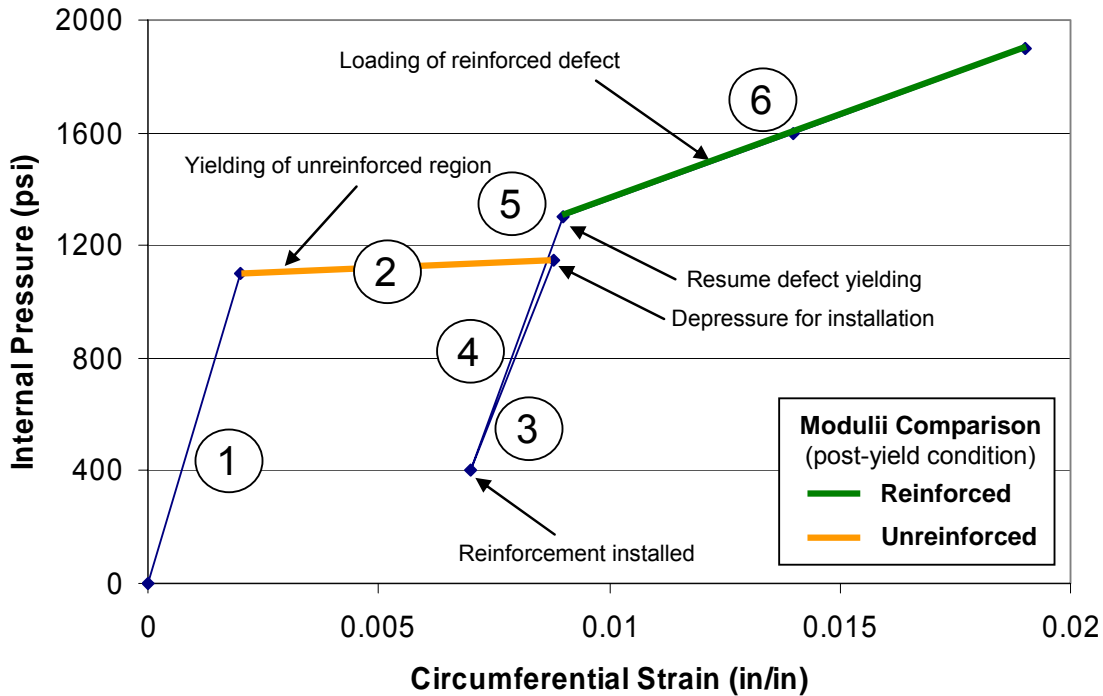

Figure 3 – Load transfer between steel carrier pipe and Clock Spring composite material [5]

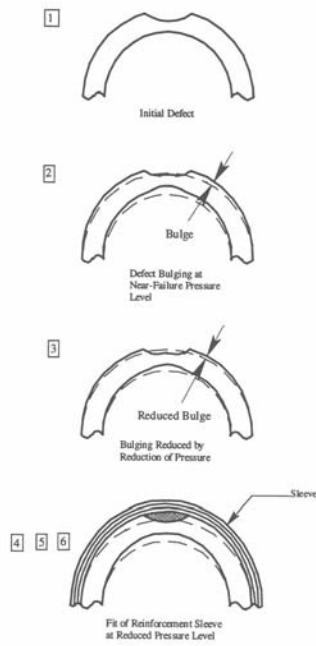

Figure 4 – Load sequence corresponding to pressure-strain data plotted in Figure 3 [5]



Figure 5 – Repair of pipe elbow fitting using Armor Plate® Pipe Wrap
 6-in standard wall elbow with 50% corrosion
 Unrepaired burst pressure of 4,532 psi • Repaired burst pressure of 6,780 psi



Figure 6 – Repair of pipe tee fitting using Armor Plate® Pipe Wrap
 6-in standard wall tee with 50% corrosion
 Unrepaired burst pressure of 6,546 psi • Repaired burst pressure of 7,500 psi